

---

# **LNA Design Using SpectreRF Application Note**

**Product Version 5.0**

**December 2003**

**September 2004**

---

© 2003-2004 Cadence Design Systems, Inc. All rights reserved.  
Printed in the United States of America.

Cadence Design Systems, Inc., 555 River Oaks Parkway, San Jose, CA 95134, USA

**Trademarks:** Trademarks and service marks of Cadence Design Systems, Inc. (Cadence) contained in this document are attributed to Cadence with the appropriate symbol. For queries regarding Cadence's trademarks, contact the corporate legal department at the address shown above or call 800.862.4522.

All other trademarks are the property of their respective holders.

**Restricted Print Permission:** This publication is protected by copyright and any unauthorized use of this publication may violate copyright, trademark, and other laws. Except as specified in this permission statement, this publication may not be copied, reproduced, modified, published, uploaded, posted, transmitted, or distributed in any way, without prior written permission from Cadence. This statement grants you permission to print one (1) hard copy of this publication subject to the following conditions:

1. The publication may be used solely for personal, informational, and noncommercial purposes;
2. The publication may not be modified in any way;
3. Any copy of the publication or portion thereof must include all original copyright, trademark, and other proprietary notices and this permission statement; and
4. Cadence reserves the right to revoke this authorization at any time, and any such use shall be discontinued immediately upon written notice from Cadence.

**Disclaimer:** Information in this publication is subject to change without notice and does not represent a commitment on the part of Cadence. The information contained herein is the proprietary and confidential information of Cadence or its licensors, and is supplied subject to, and may be used only by Cadence's customer in accordance with, a written agreement between Cadence and its customer. Except as may be explicitly set forth in such agreement, Cadence does not make, and expressly disclaims, any representations or warranties as to the completeness, accuracy or usefulness of the information contained in this document. Cadence does not warrant that use of such information will not infringe any third party rights, nor does Cadence assume any liability for damages or costs of any kind that may result from use of such information.

**Restricted Rights:** Use, duplication, or disclosure by the Government is subject to restrictions as set forth in FAR52.227-14 and DFAR252.227-7013 et seq. or its successor.

---

# Contents

---

<u>Low Noise Amplifier Design Measurements</u> .....	5
<u>Purpose</u> .....	5
<u>Audience</u> .....	5
<u>Overview</u> .....	5
<u>Introduction to LNAs</u> .....	5
<u>Testbenches for Single-Ended and Double-Ended LNAs</u> .....	6
<u>LNA Measurements and Design Specifications</u> .....	10
<u>Power Consumption and Supply Voltage</u> .....	10
<u>Gain</u> .....	10
<u>Noise in LNAs</u> .....	14
<u>Input and Output Impedance Matching</u> .....	16
<u>Reverse Isolation</u> .....	16
<u>Stability</u> .....	17
<u>Linearity</u> .....	18
<u>Example LNA Measurements</u> .....	18
<u>Example LNA Schematic</u> .....	19
<u>Small Signal Gain (SP)</u> .....	20
<u>Small Signal Stability (SP)</u> .....	26
<u>Small Signal Noise (SP and Noise)</u> .....	30
<u>Input and Output Matching (SP)</u> .....	32
<u>Large Signal Noise Simulation (PSS and Pnoise)</u> .....	33
<u>Gain Compression (Swept PSS)</u> .....	34
<u>Harmonic Distortion (PSS)</u> .....	36
<u>IP3 Simulation (PSS and PAC or QPSS)</u> .....	37
<u>Conclusion</u> .....	41
<u>Reference</u> .....	42

# LNA Design Using SpectreRF

---

---

# Low Noise Amplifier Design Measurements

---

The procedures described in this application note are deliberately broad and generic. Your specific design might require procedures that are slightly different from those described here.

## Purpose

This application note describes how to use SpectreRF in the Analog Design Environment to measure parameters which are important in design verification of Low Noise Amplifiers, or LNAs.

## Audience

Users of SpectreRF in the Analog Design Environment.

## Overview

This application note describes a basic set of the most useful measurements for LNAs.

## Introduction to LNAs

The first stage of a receiver is typically a low-noise amplifier (LNA), whose main function is to provide enough gain to overcome the noise of subsequent stages (for example, in the mixer or IF amplifier). Aside from providing enough gain while adding as little noise as possible, an LNA should accommodate large signals without distortion, offer a large dynamic range, and present good matching to its input and output, which is extremely important if a passive band-select filter and image-reject filter precedes and succeeds the LNA, since the transfer characteristics of many filters are quite sensitive to the quality of the termination.

## LNA Design Using SpectreRF

### Low Noise Amplifier Design Measurements

---

**Figure 1-1 An LNA in a Heterodyne Receiver**

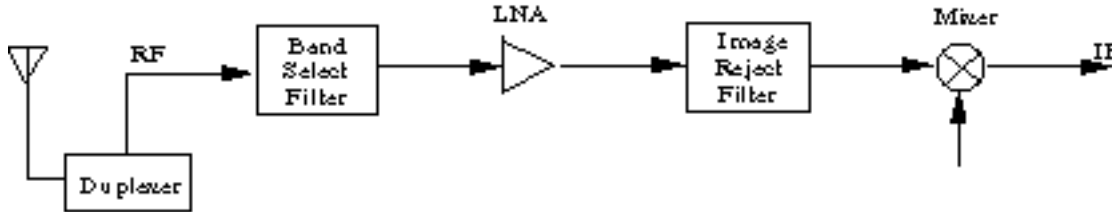

Figure 1-1 shows an LNA used in a heterodyne receiver. The band-select filter before the LNA rejects the out-of-band interferers. The image reject filter (preselected) after the LNA attenuates the image which is  $2\omega_{IF}$  away from the desired band.

Table 1-1 lists typically acceptable values for the performance metrics of LNAs used in heterodyne architectures.

**Table 1-1 Typical LNA Characteristics in Heterodyne Systems**

Measurement	Acceptable Value
NF	2 dB
IIP3	-10 dBm
Gain	15 dB
Input and Output Impedance	50 $\Omega$
Input and Output Return Loss	-15 dB
Reverse Isolation	20 dB
Stability Factor	>1

LNA design is a compromise among power, noise, linearity, gain, stability, input and output matching, and dynamic range. They are characterized by the design specifications in Table 1-1.

## Testbenches for Single-Ended and Double-Ended LNAs

Figure 1-2 shows a generic two-port amplifier model. Its input and output are each terminated by a resistive port, like an amplifier measurement using a network analyzer.

## LNA Design Using SpectreRF

### Low Noise Amplifier Design Measurements

---

**Figure 1-2 A Generic Two-Port LNA**

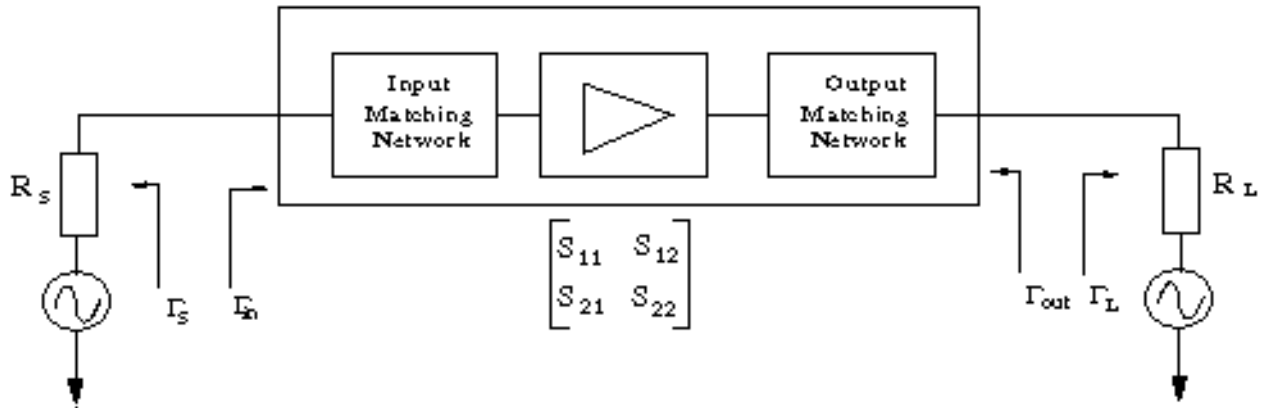

The LNA is characterized by the scattering matrix in Equation 1-1.

$$(1-1) \quad \begin{bmatrix} b_S \\ b_L \end{bmatrix} = \begin{bmatrix} S_{11} & S_{12} \\ S_{21} & S_{22} \end{bmatrix} \begin{bmatrix} a_S \\ a_L \end{bmatrix}$$

where

- $b_S$  and  $b_L$  are the reflected wave from the input and output of the LNA
- $a_S$  and  $a_L$  are the incident wave to the input and output of the LNA

They are defined in terms of the terminal voltage and current as follows

$$a_S = \frac{V_{in}}{2\sqrt{R_s}} + \frac{\sqrt{R_s}}{2} I_{in}$$

$$b_S = \frac{V_{in}}{2\sqrt{R_s}} - \frac{\sqrt{R_s}}{2} I_{in}$$

## LNA Design Using SpectreRF

### Low Noise Amplifier Design Measurements

---

$$a_L = \frac{V_{out}}{2\sqrt{R_L}} + \frac{\sqrt{R_L}}{2} I_{out}$$

$$b_L = \frac{V_{out}}{2\sqrt{R_L}} - \frac{\sqrt{R_L}}{2} I_{out}$$

Spectre normalizes the LNA scattering matrix with respect to the source and load port resistance. Therefore, the source reflection coefficient  $\Gamma_S$  and load reflection coefficient  $\Gamma_L$  are both zero.

From network theory, the input and output reflection coefficients are expressed in Equations [1-2](#) and [1-3](#).

$$(1-2) \quad \Gamma_{in} = S_{11} + \frac{S_{21}S_{12}\Gamma_L}{1 - S_{22}\Gamma_L}$$

$$(1-3) \quad \Gamma_{out} = S_{22} + \frac{S_{12}S_{21}\Gamma_S}{1 - S_{11}\Gamma_S}$$

The LNA scattering matrix is normalized in terms of the source and load resistance in Equation [1-4](#).

$$(1-4) \quad \Gamma_S = \Gamma_L = 0$$

Thus, the input and output reflection coefficients are simply expressed in Equations [1-5](#) and [1-6](#).

$$(1-5) \quad \Gamma_{in} = S_{11}$$

$$(1-6) \quad \Gamma_{out} = S_{22}$$

## LNA Design Using SpectreRF

### Low Noise Amplifier Design Measurements

---

The main challenge of LNA design lies in the design of the input/output matching network to render  $\Gamma_{in}$  and  $\Gamma_{out}$  close to zero so that the LNA is matched to the source and load ports.

With the knowledge of a generic LNA model, Figure 1-3 shows the testbench for a single-ended LNA. The capacitors are DC decoupling capacitors that eliminate the effect of the port resistor on the LNA's DC bias. They are added when necessary.

**Figure 1-3 Testbench for a Single-Ended LNA**

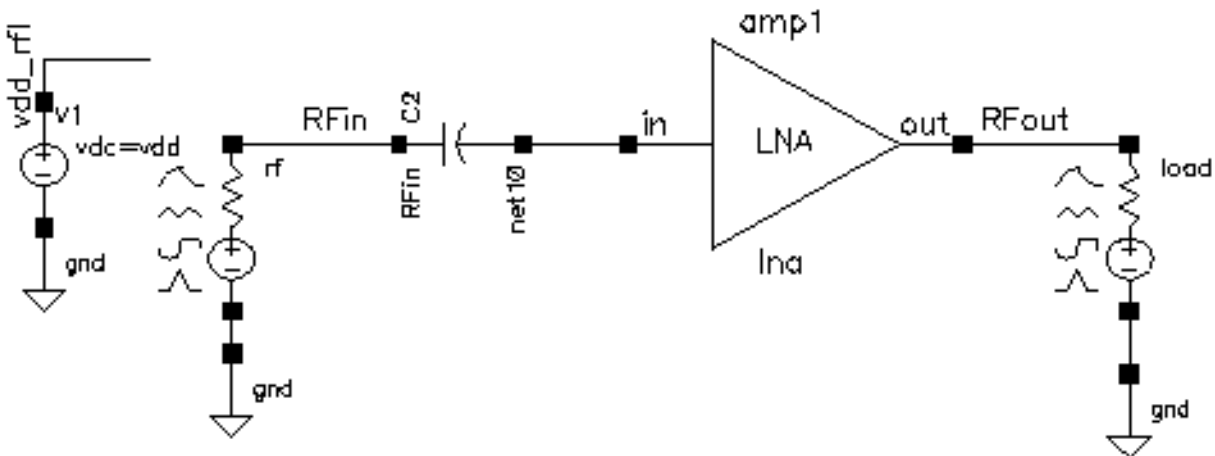
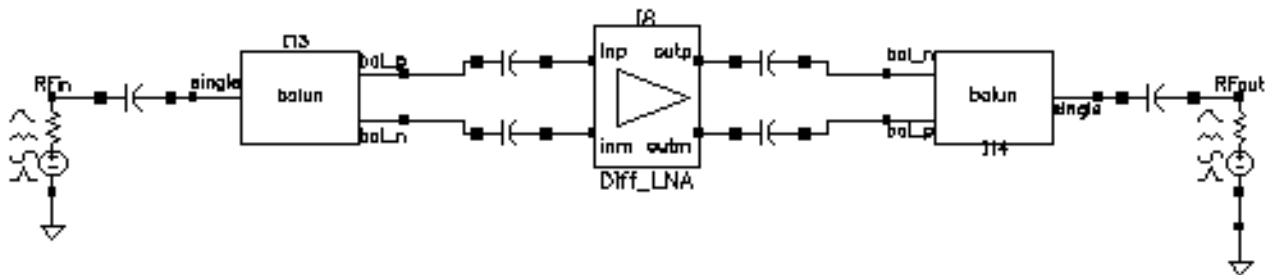

Figure 1-4 shows the testbench for a differential LNA. The baluns used in the testbench are three-port devices. The baluns convert the input signal-ended signals to the differential signals. They also perform the resistance transformation.

**Figure 1-4 Testbench for a Double-Ended LNA**



The balun's Verilog<sup>®</sup>-A model is in rfLib. Its syntax is

```
balun(single, bal_p, bal_n) rin = 50 rout =50 loss = 0
```

The balun's scattering matrix is shown in Equation [1-7](#).

$$(1-7) \quad S = \frac{1}{\sqrt{2}} \begin{bmatrix} 0 & p & -p \\ p & 0 & 0 \\ -p & 0 & 0 \end{bmatrix}$$

where  $p$  is defined in Equation [1-8](#).

$$(1-8) \quad p = 10^{-\frac{loss}{20}}$$

You specify its input and output resistance and insertion loss in dB.

## LNA Measurements and Design Specifications

### Power Consumption and Supply Voltage

You must trade off gain, distortion, and noise performance against power dissipation. Total power dissipation for an operating LNA circuit should be within its design budget. Since most LNAs are operated in Class-A mode, power consumption is easily available by multiplying the DC supply voltage by the DC operating point current. Selecting the operating point is a critical stage of LNA design which affects the power consumption, noise performance, IP3, and dynamic range.

### Gain

Three power gain definitions appear in the literature and are commonly used in LNA design.

- $G_T$ , transducer power gain
- $G_P$ , operating power gain
- $G_A$ , available power gain

Besides these three gain definitions, there are three additional gain definitions you can use to evaluate the LNA design.

## LNA Design Using SpectreRF

### Low Noise Amplifier Design Measurements

---

- $G_{umx}$ , maximum unilateral transducer power gain
- $G_{max}$ , maximum transducer power gain
- $G_{msg}$ , maximum stability gain

Besides these six gain definitions, there are two gain circles that are helpful to the design of input and output matching networks.

- $GPC$ , power gain circle
- $GAC$ , available gain circle

### Transducer Power Gain

Transducer power gain,  $G_T$ , is defined as the ratio between the power delivered to the load and the power available from the source.

$$(1-9) \quad G_T = \frac{1 - |\Gamma_s|^2}{|1 - S_{11}\Gamma_s|^2} |S_{21}|^2 \frac{1 - |\Gamma_L|^2}{|1 - \Gamma_{out}\Gamma_L|^2}$$

In the test environment, from [Equation 1-4](#) on page 8, you have

$$(1-10) \quad G_T = |S_{21}|^2$$

### Operating Power Gain

Operating power gain,  $G_P$ , is defined as the ratio between the power delivered to the load and the power input to the network.

$$(1-11) \quad G_P = \frac{1}{1 - |\Gamma_{in}|^2} |S_{21}|^2 \frac{1 - |\Gamma_L|^2}{|1 - S_{22}\Gamma_L|^2}$$

## LNA Design Using SpectreRF

### Low Noise Amplifier Design Measurements

---

In the test environment, from Equations [1-4](#) and [1-5](#) on page 8, you have

$$(1-12) \quad G_P = \frac{1}{1 - |S_{11}|^2} |S_{21}|^2$$

#### Available Power Gain

Available power gain,  $G_A$ , is defined as the ratio between the power available from the network and the power available from the source.

$$(1-13) \quad G_A = \frac{1 - |\Gamma_s|^2}{|1 - S_{11}\Gamma_s|^2} |S_{21}|^2 \frac{1}{1 - |\Gamma_{out}|^2}$$

In the test environment, from Equations [1-4](#) and [1-6](#) on page 8, you have

$$(1-14) \quad G_A = |S_{21}|^2 \frac{1}{1 - |S_{22}|^2}$$

Because the power available from the source is greater than the power input to the LNA network,  $G_P > G_T$ . The closer the two gains are, the better the input matching is. Similarly, because the power available from the LNA network is greater than the power delivered to the load,  $G_A > G_T$ . The closer the two gains are, the better the output matching is.

#### Maximum Unilateral Transducer Power Gain

Maximum unilateral transducer power gain,  $G_{umx}$ , is the transducer power gain when you assume that the reverse coupling of the LNA,  $S_{12}$ , is zero, and the source and load impedances are conjugately matched to the LNA. That is  $\Gamma_S = S_{11}^*$  and  $\Gamma_L = S_{22}^*$ . If  $S_{12} = 0$ ,

## LNA Design Using SpectreRF

### Low Noise Amplifier Design Measurements

---

from Equations [1-2](#) and [1-3](#), the input and output reflection coefficients are  $\Gamma_{in} = S_{11}$  and  $\Gamma_{out} = S_{22}$ . Thus from [Equation 1-9](#) on page 11, you get [Equation 1-15](#).

$$(1-15) \quad G_{umx} = \frac{1}{|1 - |S_{11}|^2|} |S_{21}|^2 \frac{1}{|1 - |S_{22}|^2|}$$

### Maximum Transducer Power Gain

Maximum transducer power gain,  $G_{max}$ , is the simultaneous conjugate matching power gain when both the input and output are conjugately matched.  $\Gamma_S = \Gamma_{in}^*$  and  $\Gamma_L = \Gamma_{out}^*$ . When the reverse coupling,  $S_{12}$ , is small,  $G_{umx}$  is close to  $G_{max}$ .

$$G_{max} = \frac{|S_{21}|}{|S_{12}|} \left( K - \sqrt{K^2 - 1} \right)$$

The stability factor,  $K$ , is defined in "[Stability](#)" on page 17.

### Maximum Stability Gain

Maximum stability gain,  $G_{msg}$ , is the maximum of  $G_{max}$  when the stability condition,  $K > 1$ , is still satisfied.

$$G_{msg} = \frac{|S_{21}|}{|S_{12}|}$$

### Power Gain Circle

Power gain circle,  $GPC$ . From Equations [1-2](#) and [1-11](#), you can see that  $G_P$  is solely a function of the load reflection  $\Gamma_L$ . Thus you can draw power gain contours on the Smith chart of  $\Gamma_L$ . The location for the peak of the contour corresponds to  $\Gamma_L$  producing the maximum  $G_P$ . You can move the peak location by changing the design of the output matching network. The best location for the contour peak is at the center of the Smith chart, that is where  $\Gamma_L = 0$ .

### Available Gain Circle

Available gain circle,  $GAC$ . From Equations [1-3](#) and [1-13](#), you can see that  $G_A$  is solely a function of the source reflection  $\Gamma_S$ . Thus you can draw available gain contours on the Smith chart of  $\Gamma_S$ . The location for the peak of the contour corresponds to  $\Gamma_S$  producing the maximum  $G_A$ . You can move the peak location by changing the design of the input matching network. The best location for the contour peak is at the center of Smith chart, that is where  $\Gamma_S = 0$ .

### Noise in LNAs

According to the Friis equation for cascaded stages, the overall noise figure is mainly determined by the first amplification stage, provided that it has sufficient gain. You achieve low noise performance by carefully selecting the low noise transistor, DC biasing point, and noise-matching at the input.

The noise performance is characterized by noise factor,  $F$ , which is defined as the ratio between the input signal-to-noise ratio and the output signal-to-noise ratio

$$(1-16) \quad F = \frac{\left(\frac{S}{N}\right)_{out}}{\left(\frac{S}{N}\right)_{in}} = \frac{N_{out}}{G_A N_{in}}$$

where

- $N_{in}$  is the available noise power from the source,  $N_{in} = kT\Delta f$
- $N_{out}$  is the available noise power to the load

According to linear noise theory, you can model the noise of a noisy two-port system with the two equivalent input noise generators.

- A series voltage source
- A shunt current source

This is shown in [Figure 1-5](#).

## LNA Design Using SpectreRF

### Low Noise Amplifier Design Measurements

---

The two noise sources are related by the correlation admittance. The noise factor,  $F$ , is described by Equation 1-17.

$$(1-17) \quad F = F_{min} + \frac{R_n}{G_S} |Y_S - Y_{opt}|^2$$

where  $R_n$  is the equivalent noise resistance of the noisy two-port system

$$R_n = \frac{\overline{e_n^2}}{4kT\Delta f}$$

The source admittance is  $Y_S = G_S + jB_S$ , the optimum source admittance is  $Y_{opt} = G_{opt} + jB_{opt}$ , and the minimum noise factor is  $F_{min}$ . The optimum source admittance  $Y_{opt}$ , the minimum noise factor  $F_{min}$ , and  $R_n$  are solely determined by the two-port circuit itself.

**Figure 1-5 Two-Port Noise Theory**

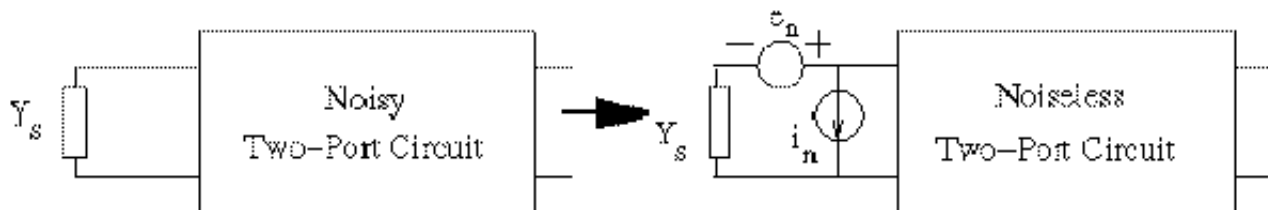

From Equation 1-17, the noise factor,  $F$ , is a function of source admittance,  $Y_S$ . Thus you can plot the noise factor contour on the source admittance Smith chart. Where  $Y_S = Y_{opt}$ , the center of the noise factor contour corresponds to  $F_{min}$ . You can move the center of the source admittance Smith chart,  $Y_{opt}$ , by changing the input matching network design. Your best choice is to move the center of the noise circles to the center of the Smith chart so that  $Y_{opt} = R_S$ .

You perform noise-matching by designing the input-matching network so that the center of the LNA's noise circles (NC) moves to the center of the source admittance Smith chart. However, as previously mentioned, in order to maximize the available gain, you should also move the center of the available gain circle (GAC) to the center of the source admittance Smith chart. These two goals might turn out to be contradictory, in which case you must compromise so that the centers of the noise circles and the gain circle are both close to the Smith chart center.

## LNA Design Using SpectreRF

### Low Noise Amplifier Design Measurements

---

Several design topologies are available to help you to balance noise and gain matching. The topologies include shunt-series feedback, common-gate and inductively-degenerated common-source [3] [4].

### Input and Output Impedance Matching

The input and output are each connected to the LNA with filters whose performance relies heavily on the terminal impedance. Furthermore, input and output matching to the source and load can maximize the gain. Input and output impedance matching is characterized by the input and output return loss.

$$20\log|\Gamma_{in}| = 20\log|S_{11}|$$

$$20\log|\Gamma_{out}| = 20\log|S_{22}|$$

You can also characterize the LNA's input and output impedance matching by the voltage standing wave ratio (VSWR):

$$VSWR_{in} = \frac{1 + |\Gamma_{in}|}{1 - |\Gamma_{in}|} = \frac{1 + |S_{11}|}{1 - |S_{11}|}$$

$$VSWR_{out} = \frac{1 + |\Gamma_{out}|}{1 - |\Gamma_{out}|} = \frac{1 + |S_{22}|}{1 - |S_{22}|}$$

Your primary design goals are to

- Minimize the return loss
- Make the VSWR close to 1

### Reverse Isolation

The reverse isolation of an LNA determines the amount of the LO signal that leaks from the mixer to the antenna. LO signal leakage arises from capacitive paths, substrate coupling, and bond wire coupling. In a heterodyne receiver, because the LO signal is  $\omega_{if}$  away from the RF signal, the image-reject and band-select filters and the LNA can all work together to significantly attenuate the LO signal leaked from the VCO.

## LNA Design Using SpectreRF

### Low Noise Amplifier Design Measurements

---

Insufficient isolation can cause feedback and even instability. Reverse isolation is characterized by the reverse transducer gain power,  $|S_{12}|^2$ . You should minimize the reverse transducer gain power as much as possible.

### Stability

In the presence of feedback paths from the output to the input, the circuit might become unstable for certain combinations of source and load impedances. An LNA design that is normally stable might oscillate at the extremes of the manufacturing or voltage variations, and perhaps at unexpectedly high or low frequencies.

The Stern stability factor characterizes circuit stability as in Equation [1-18](#).

$$(1-18) \quad K = \frac{1 + |\Delta|^2 - |S_{11}|^2 - |S_{22}|^2}{2|S_{21}||S_{12}|}$$

where

$$\Delta = S_{11}S_{22} - S_{12}S_{21}$$

When  $K > 1$  and  $\Delta < 1$ , the circuit is unconditionally stable. That is, the circuit does not oscillate with any combination of source and load impedances. You should perform the stability evaluation for the S parameters over a wide frequency range to ensure that  $K$  remains greater than one at all frequencies.

As the coupling ( $S_{12}$ ) decreases, that is as reverse isolation increases, stability improves. You might use techniques such as resistive loading and neutralization to improve stability for an LNA. [2].

Equation [1-18](#) is valid for small-signal stability. If the circuit is un-conditionally stable under small-signal conditions, the circuit is less likely to be unstable when the input signal is large.

Aside from the two metrics  $K$  and  $\Delta$ , you can also use the source and load stability circles to check for LNA stability.

- The input stability circle draws the circle  $|\Gamma_{out}| = 1$  on the Smith chart of  $\Gamma_S$ .
- The output stability circle draws the circle  $|\Gamma_{in}| = 1$  on the Smith chart of  $\Gamma_L$ .

## LNA Design Using SpectreRF

### Low Noise Amplifier Design Measurements

---

The non-stable regions of the two circles should be far away from the center of the Smith chart. In fact the non-stable regions are better located outside the Smith chart circles.

## Linearity

Nonlinear LNAs can corrupt the RF input signal and cause the types of distortion [3] described in Table 1-2.

**Table 1-2 RF Input Signal Distortion In Nonlinear LNAs**

<b>Harmonic Distortion</b>	A nonlinear LNA might generate output with high order harmonics when the input is a pure sinusoid.
<b>Cross Modulation</b>	A nonlinear LNA might transfer the modulation on one channel's carrier to another channel's carrier.
<b>Blocking</b>	In a nonlinear LNA, one large signal on one channel might desensitize the amplification of a small signal on neighboring channels. Many RF receivers must be able to withstand blocking signals 60 to 70 dB greater than the wanted signal.
<b>Gain Compression</b>	In a nonlinear LNA, gain decreases as input power increases because of transistor saturation.
<b>Intermodulation</b>	In a nonlinear LNA, two large signals (interferers) on two adjacent channels might generate the 3rd-order intermodulation component which falls into the bandwidth of neighboring channels.

---

LNA linearity is characterized by the 1 dB compression point (P1 dB) and the 3rd order interception point (IP3).

## Example LNA Measurements

To test an LNA, place it into one of the testbenches described in "[Testbenches for Single-Ended and Double-Ended LNAs](#)" on page 6. You can then perform various analyses to determine the gain, noise, power, linearity, stability and matching performance for the LNA.

This section demonstrates how to set up the required SpectreRF analyses and to make measurements on LNAs. It explains how to extract the design parameters from the data generated by the analyses.



## Small Signal Gain (SP)

### Analysis - S Parameter (SP) Analysis

The S Parameter (SP) analysis is the most useful linear small signal analysis for LNAs. Set up an SP analysis by specifying the input and output ports and the range of sweep frequencies.

### Results - Displayed as Gain Plots

Once you know the S parameters for the LNA, you can extract and plot the following gain measurements.

- $G_T$ , transducer power gain
- $G_P$ , operating power gain
- $G_A$ , available power gain

Figure [1-7](#) displays these gain curves for the differential-ended CMOS LNA.

## LNA Design Using SpectreRF

### Low Noise Amplifier Design Measurements

Figure 1-7 Three Gains Simulated by SpectreRF

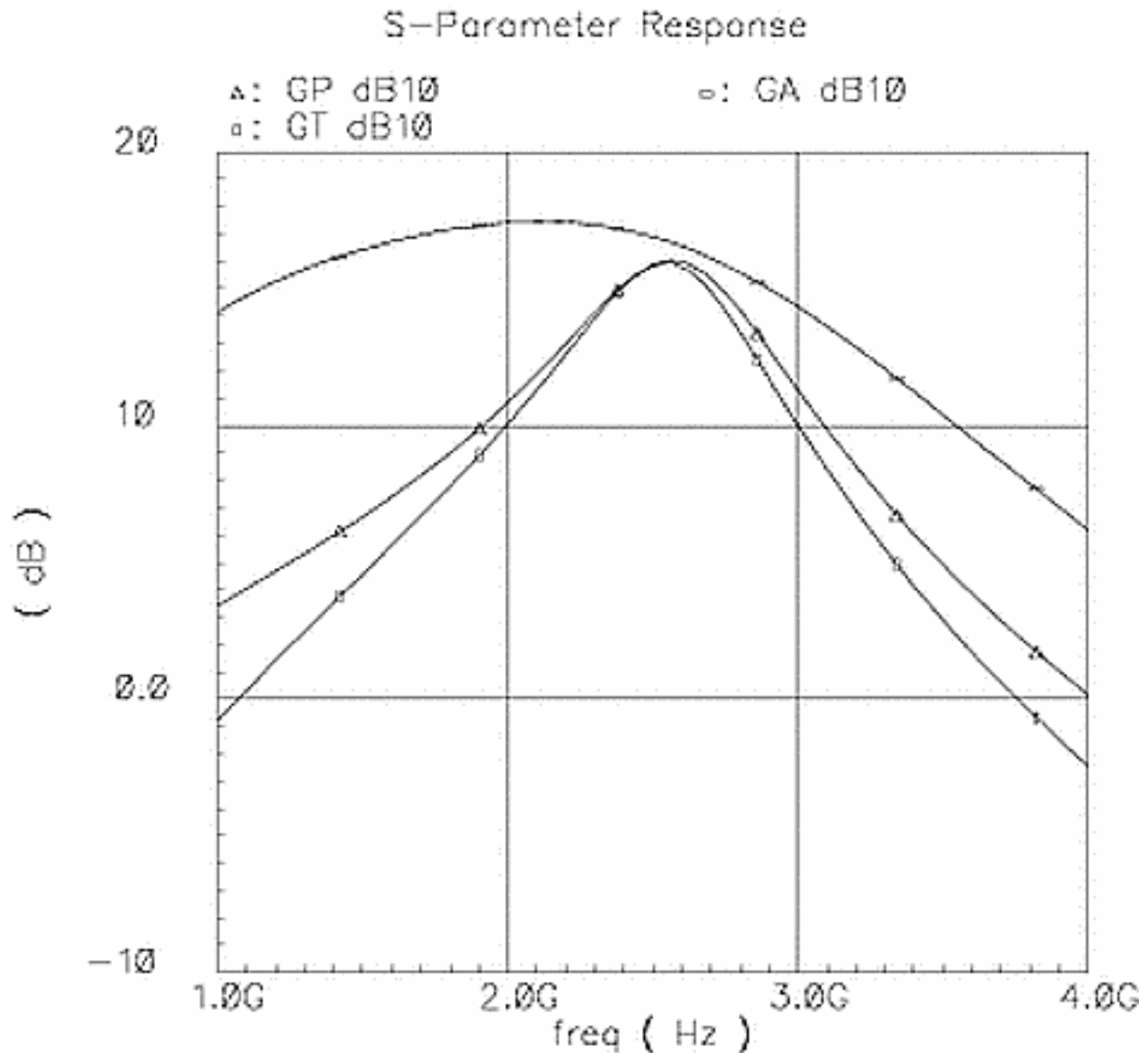

In Figure 1-7,  $G_T$  is the smallest gain. This is expected from the discussion about “Gain” on page 10. The power gain  $G_P$  is closer to the transducer gain  $G_T$  than the available gain  $G_A$  which means the input matching network is properly designed. That is,  $S_{11}$  is close to zero.

You can also extract and plot the following gain measurements.

- $G_{umg}$ , maximum unilateral power gain
- $G_{max}$ , maximum power gain

## LNA Design Using SpectreRF

### Low Noise Amplifier Design Measurements

---

- $G_{msg}$ , maximum stability gain

Figure 1-8 displays these gain curves for the differential-ended CMOS LNA.

**Figure 1-8 Three More Gains Simulated by SpectreRF**

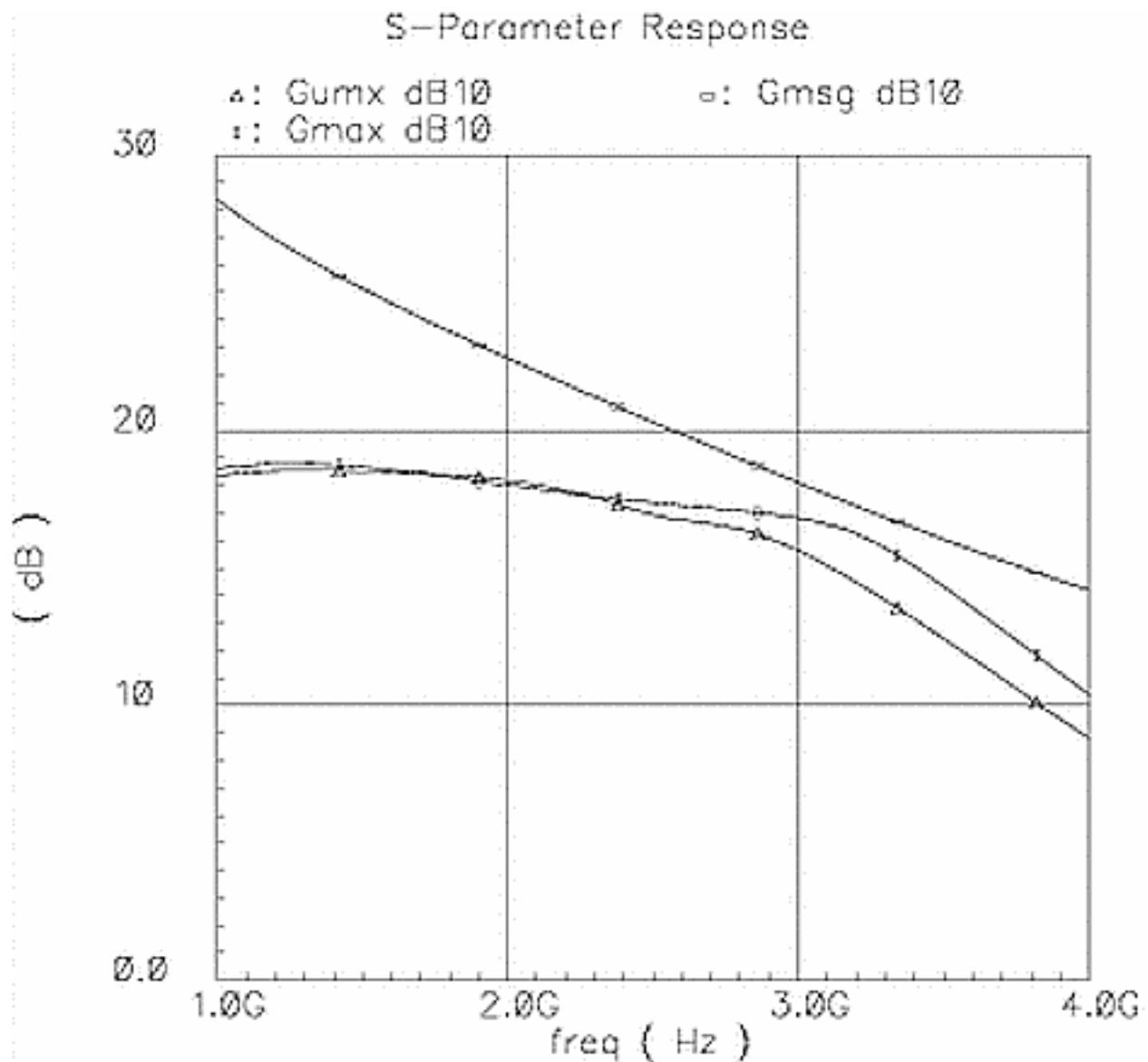

In Figure 1-8,  $G_{umx}$  is very close to  $G_{max}$  which means the reverse coupling,  $S_{12}$ , is small. Obviously  $G_{msg}$  is the largest among the six gains plotted in Figures 1-7 and 1-8.

## LNA Design Using SpectreRF

### Low Noise Amplifier Design Measurements

---

Comparing  $G_T$  calculated from [Equation 1-10](#) on page 11 with  $G_{umx}$  calculated from [Equation 1-15](#) on page 13, the difference shows the maximum source and load matching gains.

$$G_{in} = \frac{1}{(1 - |S_{11}|^2)}$$

$$G_{out} = \frac{1}{(1 - |S_{22}|^2)}$$

### Results - Displayed as Gain Circles

SpectreRF also offers two gain circles.

- GPC draws the  $G_P$  contour on the Smith chart of  $\Gamma_L$
- GAC draws the  $G_A$  contour on the Smith chart of  $\Gamma_S$ .

# LNA Design Using SpectreRF

## Low Noise Amplifier Design Measurements

Figure 1-9 Power Gain Contour (GPC)

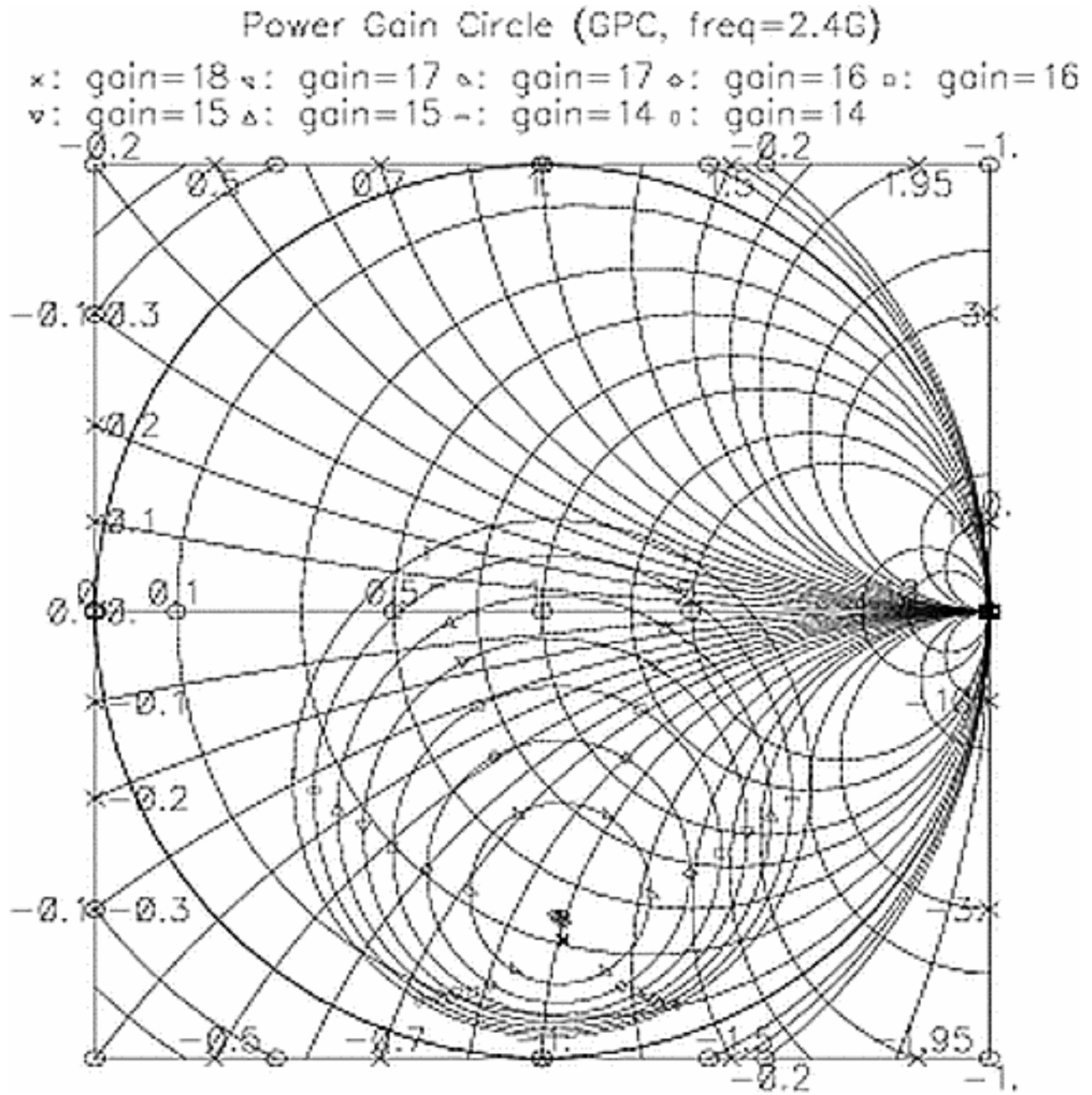

## LNA Design Using SpectreRF

### Low Noise Amplifier Design Measurements

**Figure 1-10 Available Gain Contour (GAC)**

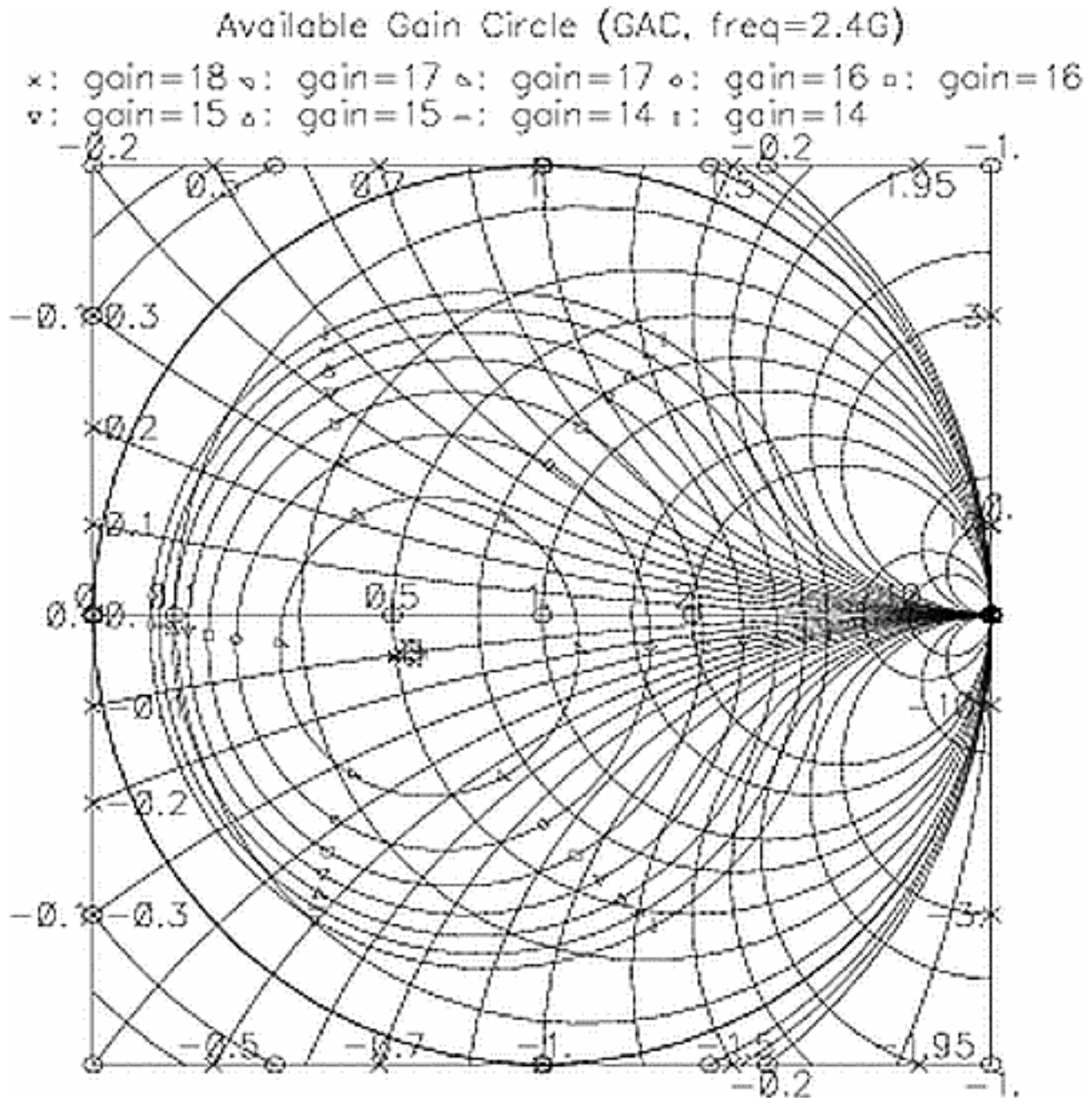

The contours in both Figures [1-9](#) and [1-10](#) are plotted for  $freq = 2.4$  GHz.

- In Figure [1-9](#),  $G_p \approx 15.5$  at  $\Gamma_L = 0$
- In Figure [1-10](#)  $G_A \approx 17.5$  at  $\Gamma_s = 0$ .

These results match the results in [Figure 1-7](#) on page 21. As has been discussed, the centers of the two contours should be located close to the centers of the Smith charts. Obviously  $\Gamma_S$  is closer.

## Small Signal Stability (SP)

### Analysis - S Parameter (SP) Analysis

Set up an SP analysis.

### Results - Stability Curves and Load and Source Stability Circles

The Stern stability factor  $K$  and  $\Delta$ , as described in "[Stability](#)" on page 17, are plotted two ways.

- The stability curves for  $K$  and  $\Delta$  are plotted with respect to frequency sweep in [Figure 1-11](#).
- The load stability circle (LSB) is plotted in [Figure 1-12](#).
- The source stability circle (SSB) is plotted in [Figure 1-13](#).

# LNA Design Using SpectreRF

## Low Noise Amplifier Design Measurements

Figure 1-11 Stability Curves

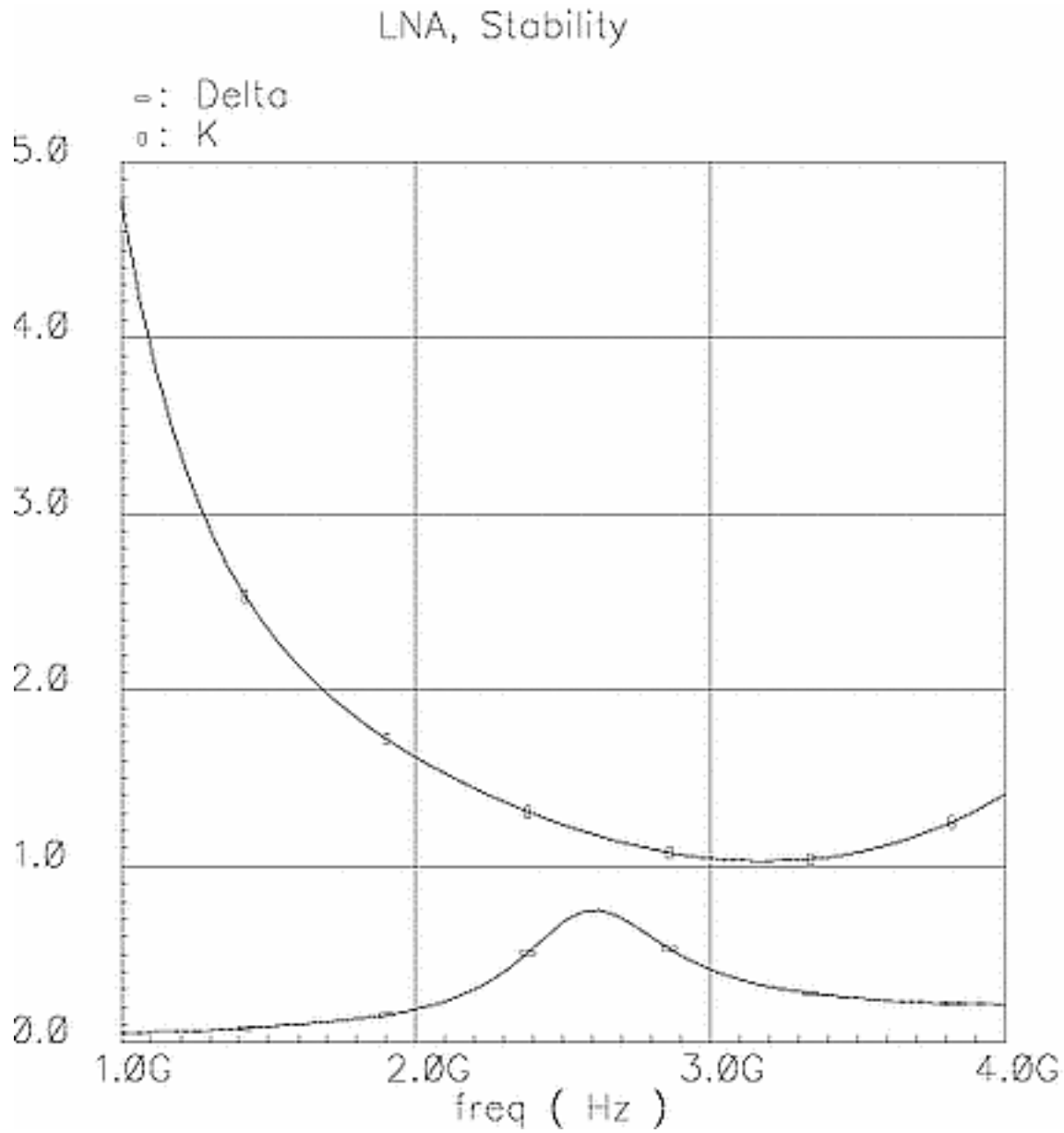

# LNA Design Using SpectreRF

## Low Noise Amplifier Design Measurements

Figure 1-12 Load Stability Circles

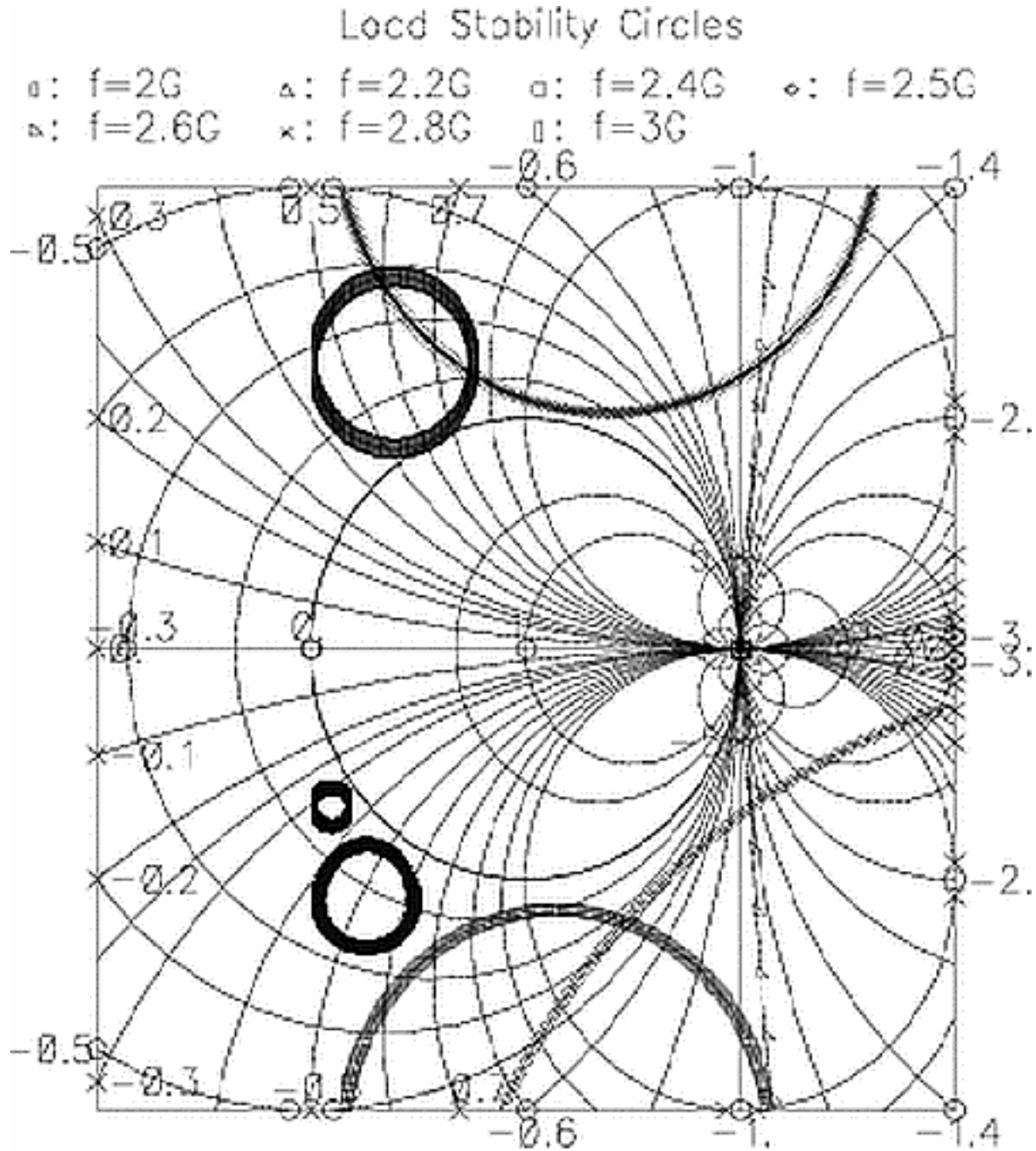

# LNA Design Using SpectreRF

## Low Noise Amplifier Design Measurements

Figure 1-13 Source Stability Circles

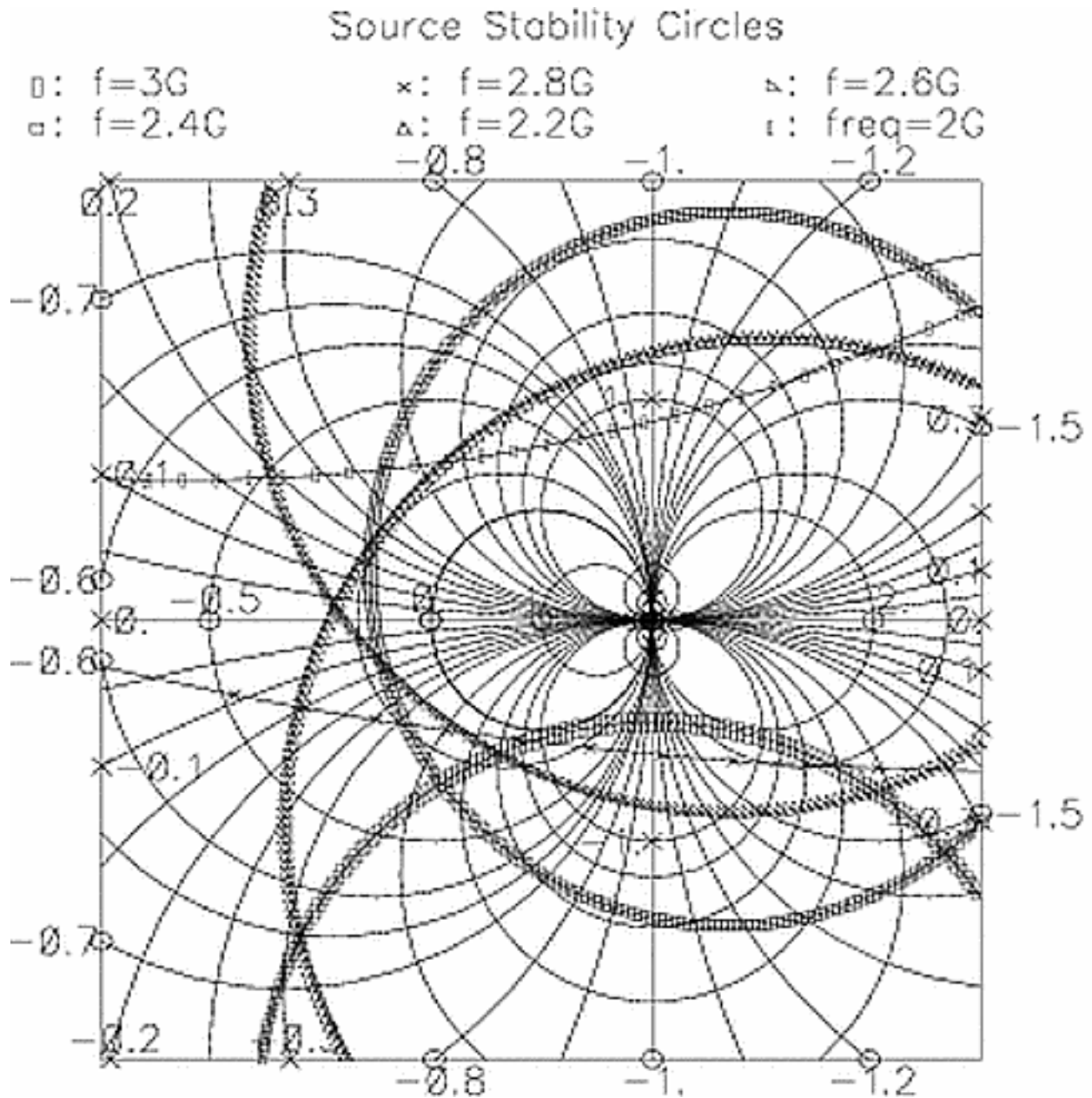

## Small Signal Noise (SP and Noise)

### Analyses - SP and Noise Analyses

Set up both SP and Noise analyses. You can obtain small signal noise when the input power level is low and the circuits are considered linear.

### Results - Noise Circles and Noise Figure

You can perform small signal noise simulation using both the SP and Noise analyses.

- The Noise analysis provides only the noise figure,  $NF$ .
- The SP analysis provides
  - $NF_{min}$ , minimum noise figure
  - $R_S$ , noise resistance
  - $G_{min}$ , optimum noise reflection coefficient
  - $Y_{opt}$ , optimum source admittance,  $Y_{opt}$ , which is related to  $G_{min}$  as shown in the equation

$$G_{min} = \frac{Y_s - Y_{opt}}{Y_s + Y_{opt}}$$

In Figure 1-14, the noise circle,  $NC$ , draws the  $NF$  on the Smith chart of the source reflection coefficient,  $\Gamma_S$ . The result in Figure 1-14 where  $\Gamma_S = 0$  and  $NF = 3$  dB matches the result in Figure 1-15. The center of the  $NC$  corresponds to  $\Gamma_S$  (that is,  $G_{min}$ ) which generates  $NF_{min}$ . The optimum location for the center of the noise circle is at the center of the Smith chart. However it is hard to center both the available gain circle,  $GAC$ , and the noise circle,  $NC$ , in the Smith chart.

## LNA Design Using SpectreRF

### Low Noise Amplifier Design Measurements

**Figure 1-14 Noise Circle**

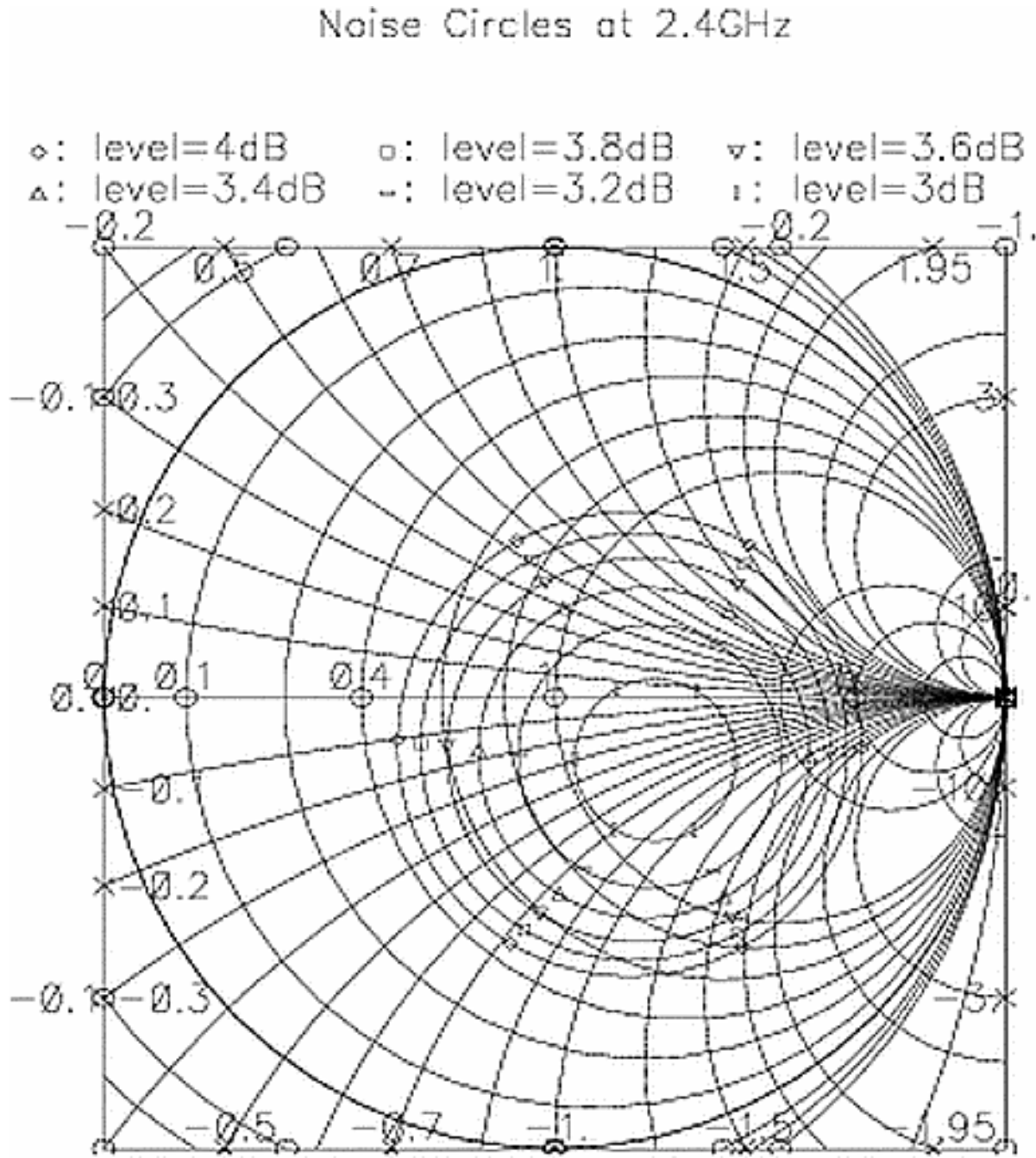

When you design an LNA, plot *NC*, *GAC*, and the source stability circle, *SSB*, together in the same plot. Use this plot to trade off the gain, noise, and stability for the input matching network design.

# LNA Design Using SpectreRF

## Low Noise Amplifier Design Measurements

Figure 1-15 Noise Figure

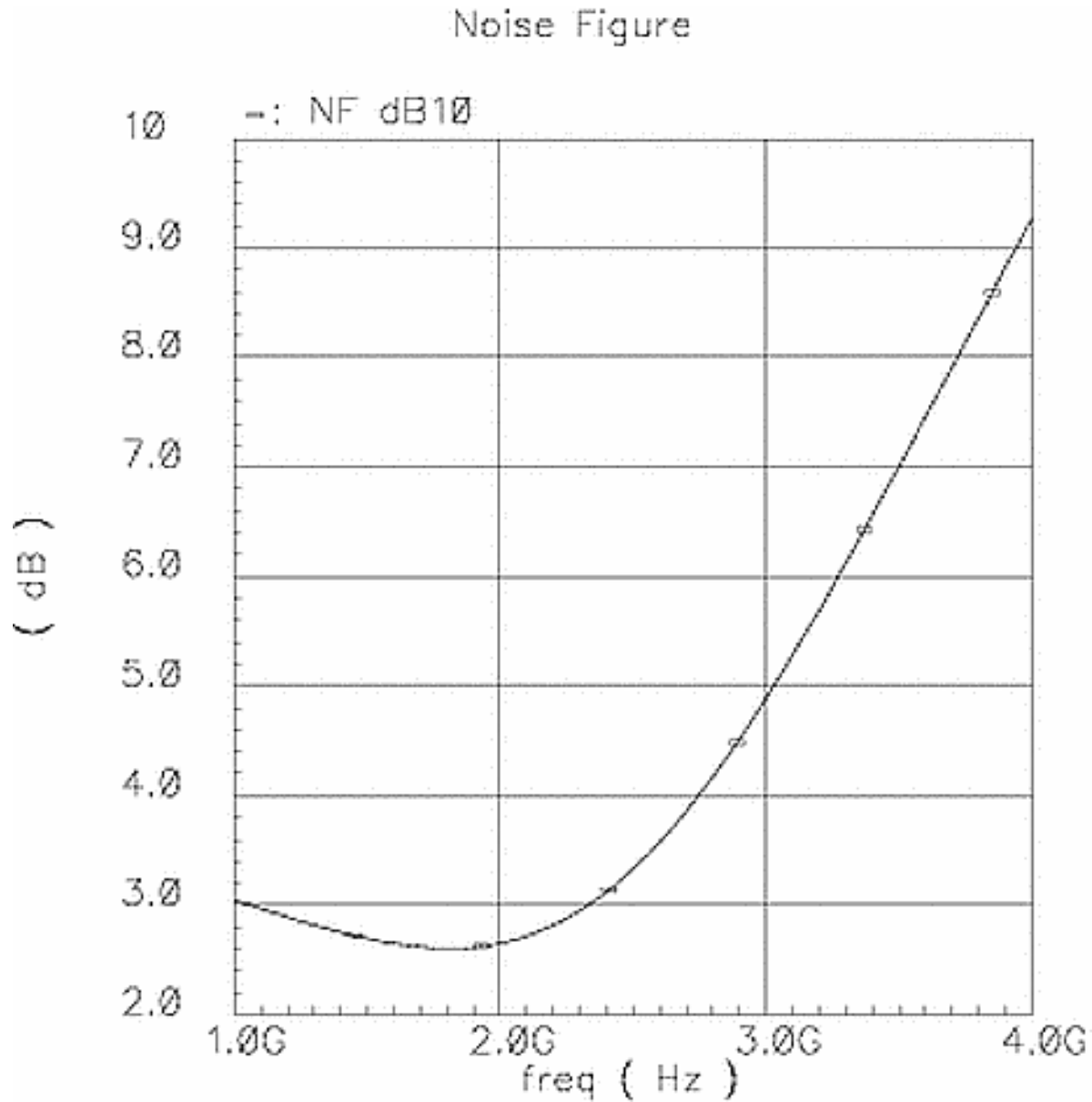

### Input and Output Matching (SP)

#### Analysis - SP

Set up and run an SP analysis.

## LNA Design Using SpectreRF

### Low Noise Amplifier Design Measurements

#### Results - Input and Output VSWR

As shown in Figure 1-16, you can plot input and output voltage standing wave ratios (VSWRs) with respect to the frequency sweep.

**Figure 1-16 Input and Output Voltage Standing Wave Ratios (VSWR)**

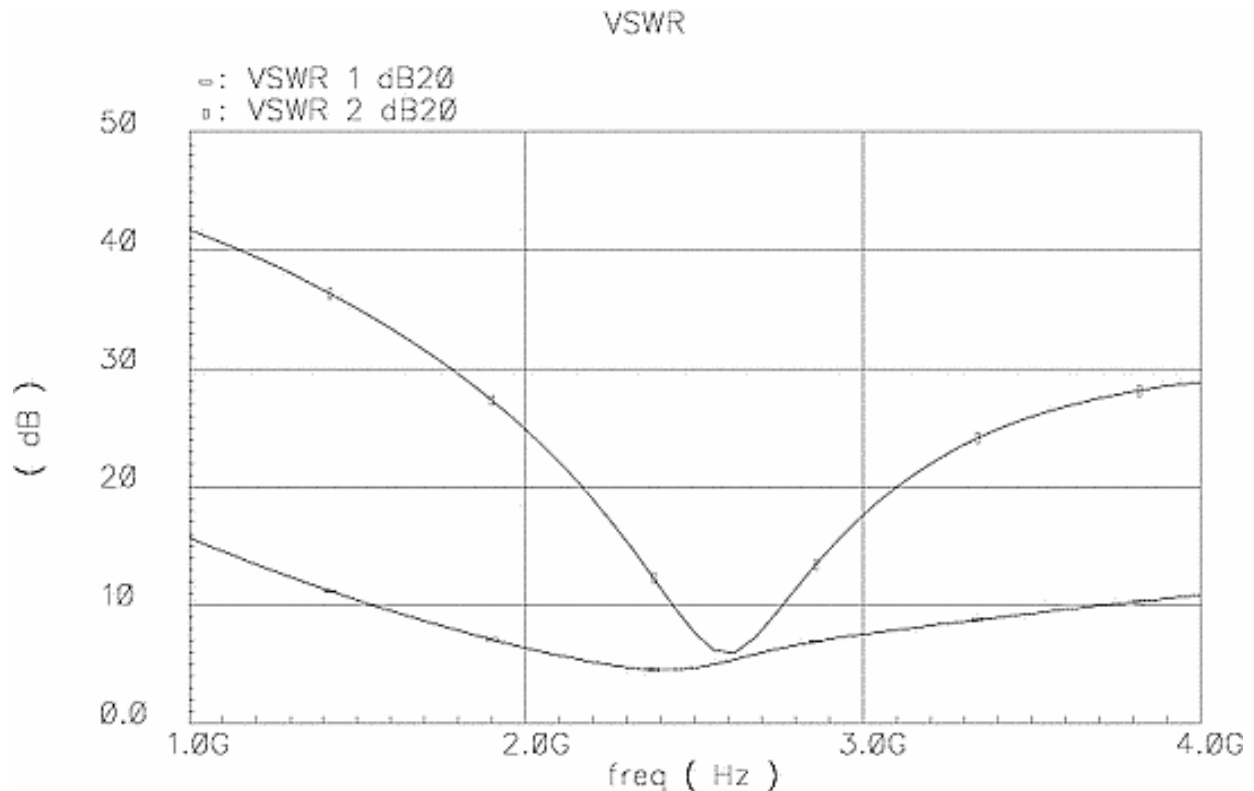

#### Large Signal Noise Simulation (PSS and Pnoise)

##### Analysis - PSS and Pnoise Analysis

Use the PSS and Pnoise analyses for large-signal and nonlinear noise analyses, where the circuits are linearized around the periodic steady-state operating point. (Use the Noise and SP analyses for small-signal and linear noise analyses, where the circuits are linearized around the DC operating point.) As the input power level increases, the circuit becomes nonlinear, the harmonics are generated and the noise spectrum is folded. Therefore, you should use the PSS and Pnoise analyses. When the input power level remains low, the NF calculated from the Pnoise, PSP, Noise, and SP analyses should all match.

## LNA Design Using SpectreRF

### Low Noise Amplifier Design Measurements

---

#### Results - Noise Factor, Noise Figure (NF), Output Noise and Noise Summary

Comparing Figure 1-15 on page 32 with Figure 1-17, the NF plot matches very well. The NF from Pnoise is slightly larger than the NF from SP because at  $P_{in} = -20$  dBm, the LNA demonstrates very weak nonlinearity and noise as other high harmonics are convoluted.

**Figure 1-17 Noise Figure Simulated by Pnoise**

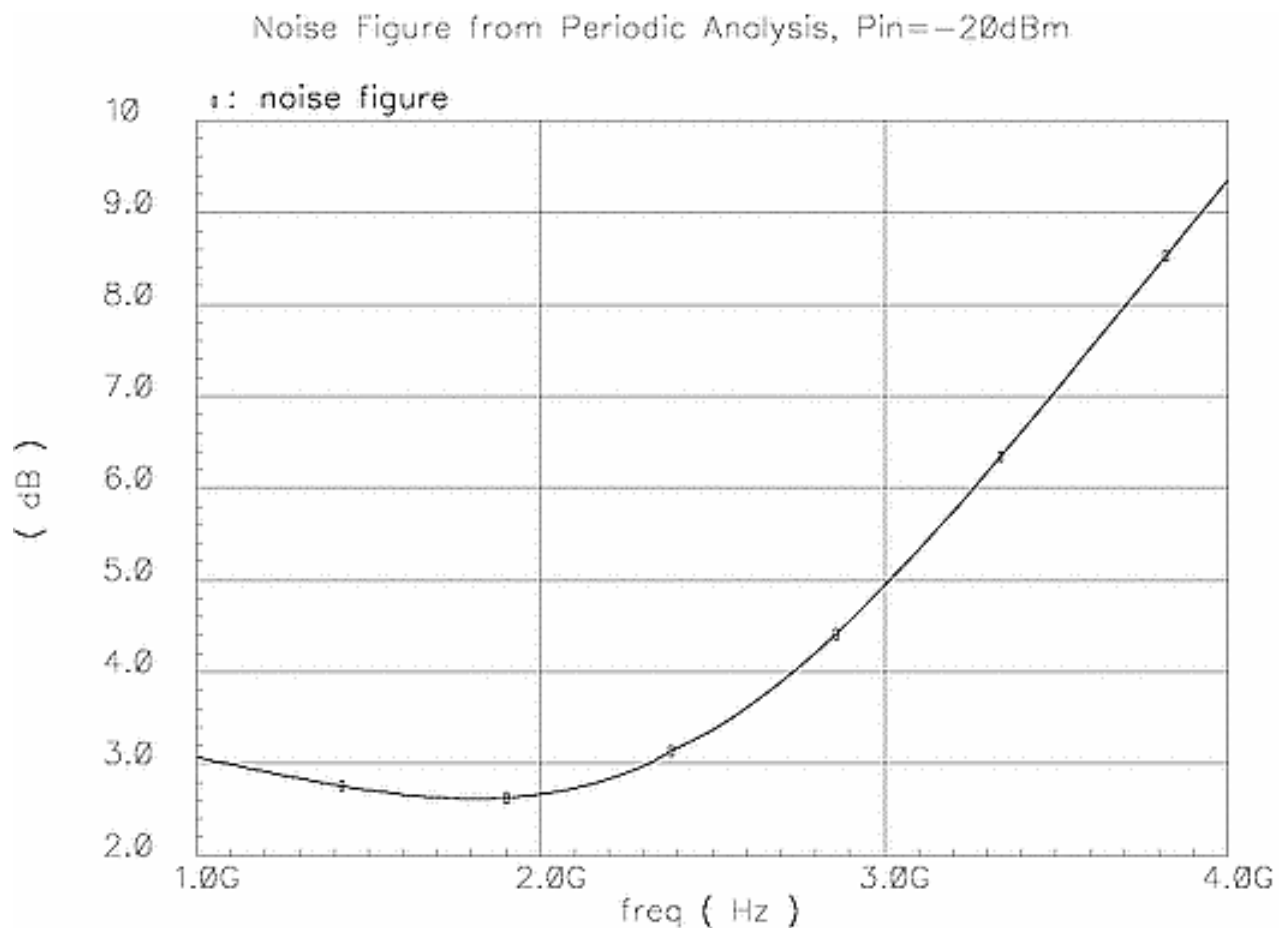

#### Gain Compression (Swept PSS)

##### Analysis - Swept PSS Analysis

Set up a swept PSS analysis that sweeps the input power level.

# LNA Design Using SpectreRF

## Low Noise Amplifier Design Measurements

### Results - Displayed as the 1 dB Compression Point

A PSS analysis calculates the operating power gain. That is, the ratio of power delivered to the load divided by the power available from the source. This gain definition is the same as that for  $G_P$ . Therefore, the gain from PSS should match  $G_P$  when the input power level is low and nonlinearity is weak.

**Figure 1-18 Gain Compression (1dB Compression)**

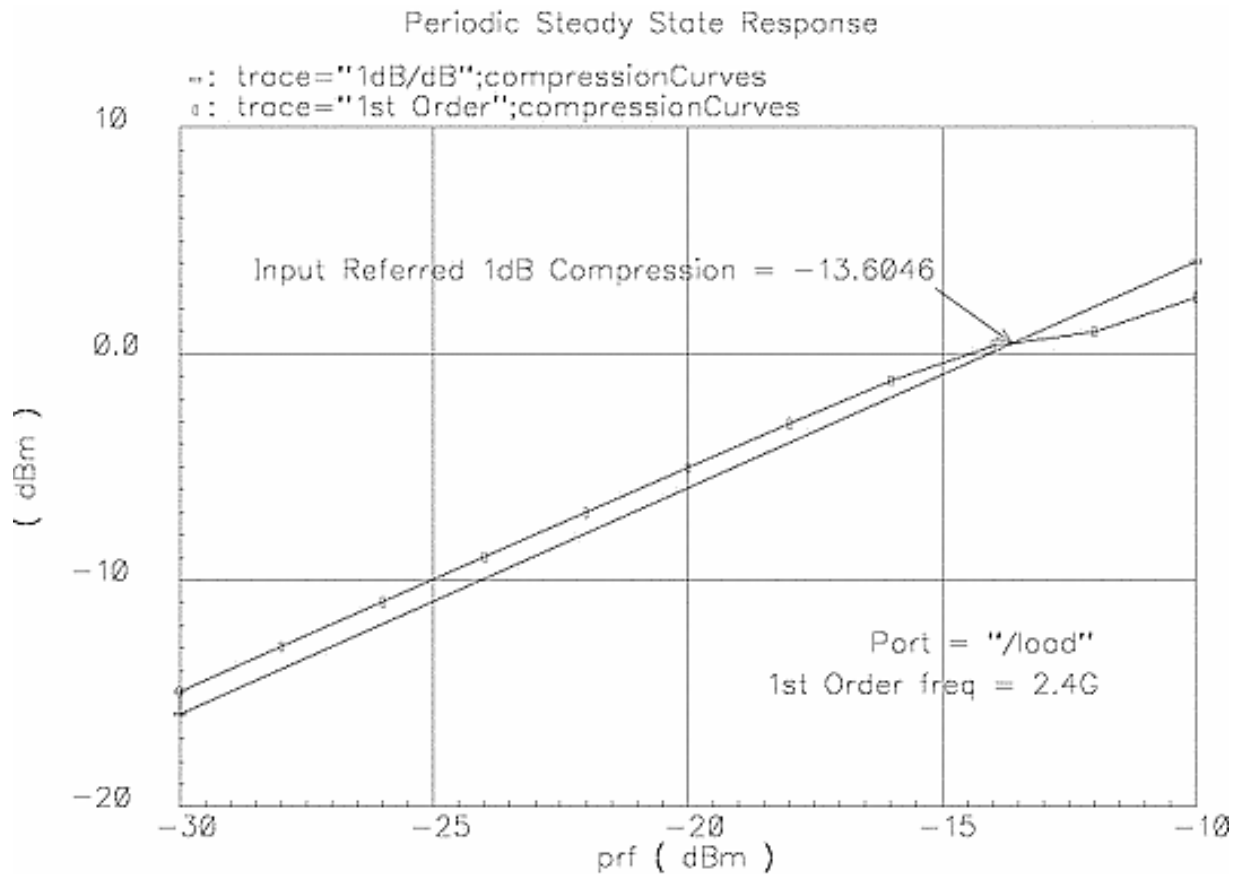

After the PSS analysis with swept input power level, plot the output power against the input power level. Determine the 1 dB compression point from the curve in Figure 1-18. The gain at -30 dBm input power level is  $-15 - (-30) = 15$  dBm which is a good match for the small signal gain.

## Harmonic Distortion (PSS)

### Analysis - The PSS Analysis

Set up a PSS analysis.

### Results - Displayed as the Output Voltage Spectrum

After the PSS analysis, you can observe the harmonic distortion of the LNA by plotting the spectrum of any node voltage. Harmonic distortion is characterized as the ratio of the power of the fundamental signal divided by the sum of the power at the harmonics. Figure [1-18](#) plots the spectrum of a load when the input power level is -20 dBm.

In Figure [1-18](#) it is obvious that the DC and all the even modes at the output are suppressed because the LNA is a differential LNA.

If you write the nonlinear response of one side amplification as

$$y(x) = \alpha_0 + \alpha_1 x + \alpha_2 x^2 + \alpha_3 x^3$$

the output is

$$y = y(x/2) - y(-x/2) = \alpha_1 x + \alpha_3 x^3 / 4$$

for the differential LNA, the common mode disturbance is rejected.

**Figure 1-19 Output Voltage Spectrum**

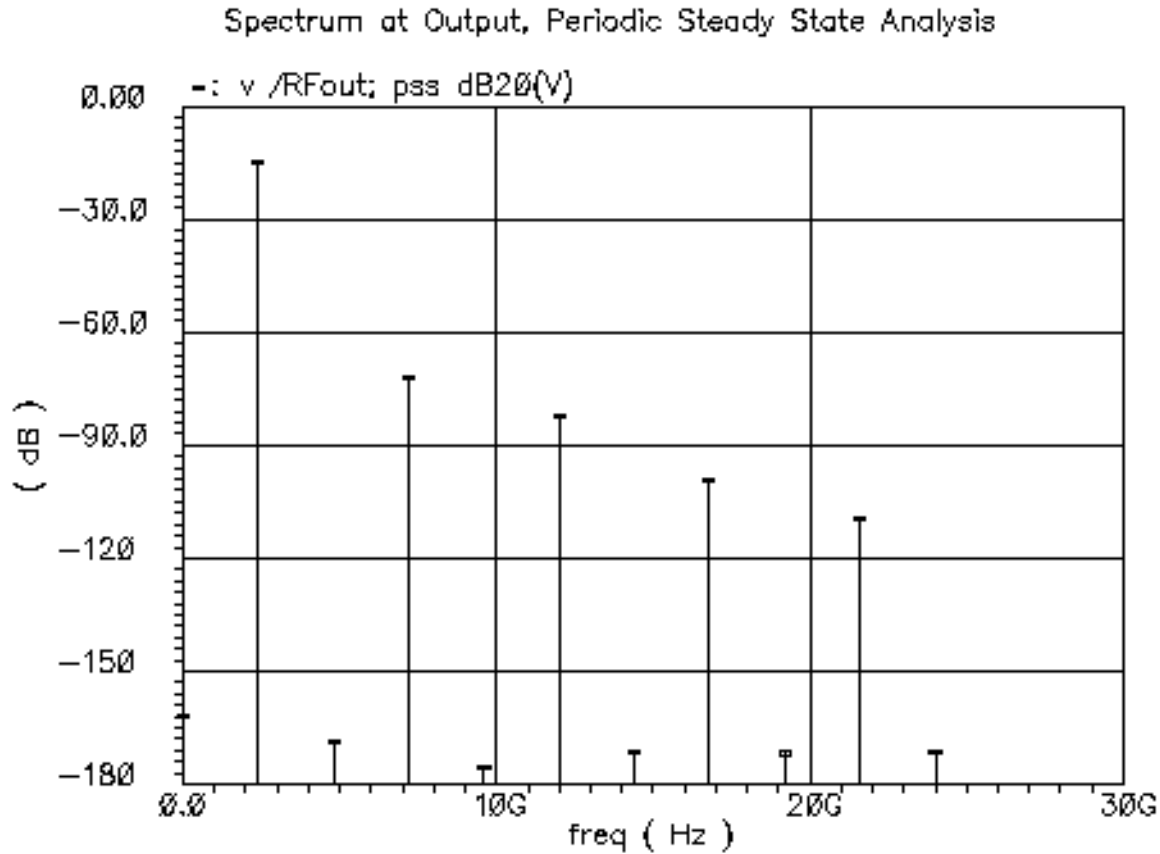

## IP3 Simulation (PSS and PAC or QPSS)

### Analyses - PSS and PAC analyses or QPSS Analysis

Set up a PSS analysis followed by a PAC analysis or set up a QPSS analysis.

### Results - IP3 Curves

Use a two-tone test to measure an IP3 curve where the two tones,  $\omega_1$  and  $\omega_2$ , with the same amplitude and coming from two adjacent channels, drive the LNA simultaneously. The IP3 is defined as the cross point of the power for the 1st order tones,  $\omega_1$  and  $\omega_2$ , and the power for the 3rd order tones,  $2\omega_1 - \omega_2$  and  $2\omega_2 - \omega_1$ , on the load.

**Figure 1-20 IP3 Theory**

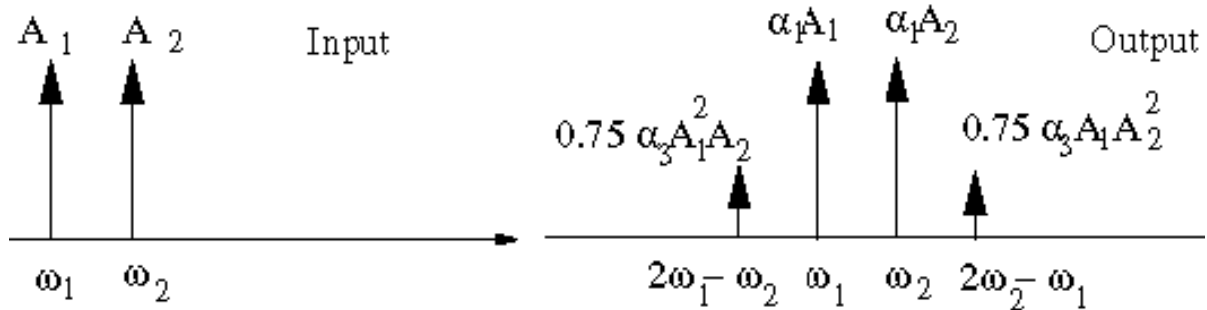

As shown in Figure 1-20, when you assume the input signal,  $x$ , as

$$x = A_1 \cos \omega_1 t + A_2 \cos \omega_2 t$$

and the nonlinear response,  $y$ , as

$$y = \alpha_1 x + \alpha_2 x^2 + \alpha_3 x^3$$

then, the linear and third order components at the output are

$$\alpha_1 A_1 \cos \omega_1 t, \quad \alpha_1 A_2 \cos \omega_2 t, \quad \frac{3\alpha_3 A_1^2 A_2}{4} \cos(2\omega_1 - \omega_2)t, \quad \frac{3\alpha_3 A_1 A_2^2}{4} \cos(2\omega_2 - \omega_1)t$$

When

$$A_1 = A_2$$

- The two first-order components have the same amplitude
- The two third-order components also have the same amplitude

Since the first-order components grow linearly and third-order components grow cubically, they eventually intercept as the input power level  $A$  increases. The third-order intercept point is the point where the two output power curves intercept as shown in Figures 1-21 and 1-22.

# LNA Design Using SpectreRF

## Low Noise Amplifier Design Measurements

**Figure 1-21 IP3 for PSS plus PAC Analysis**

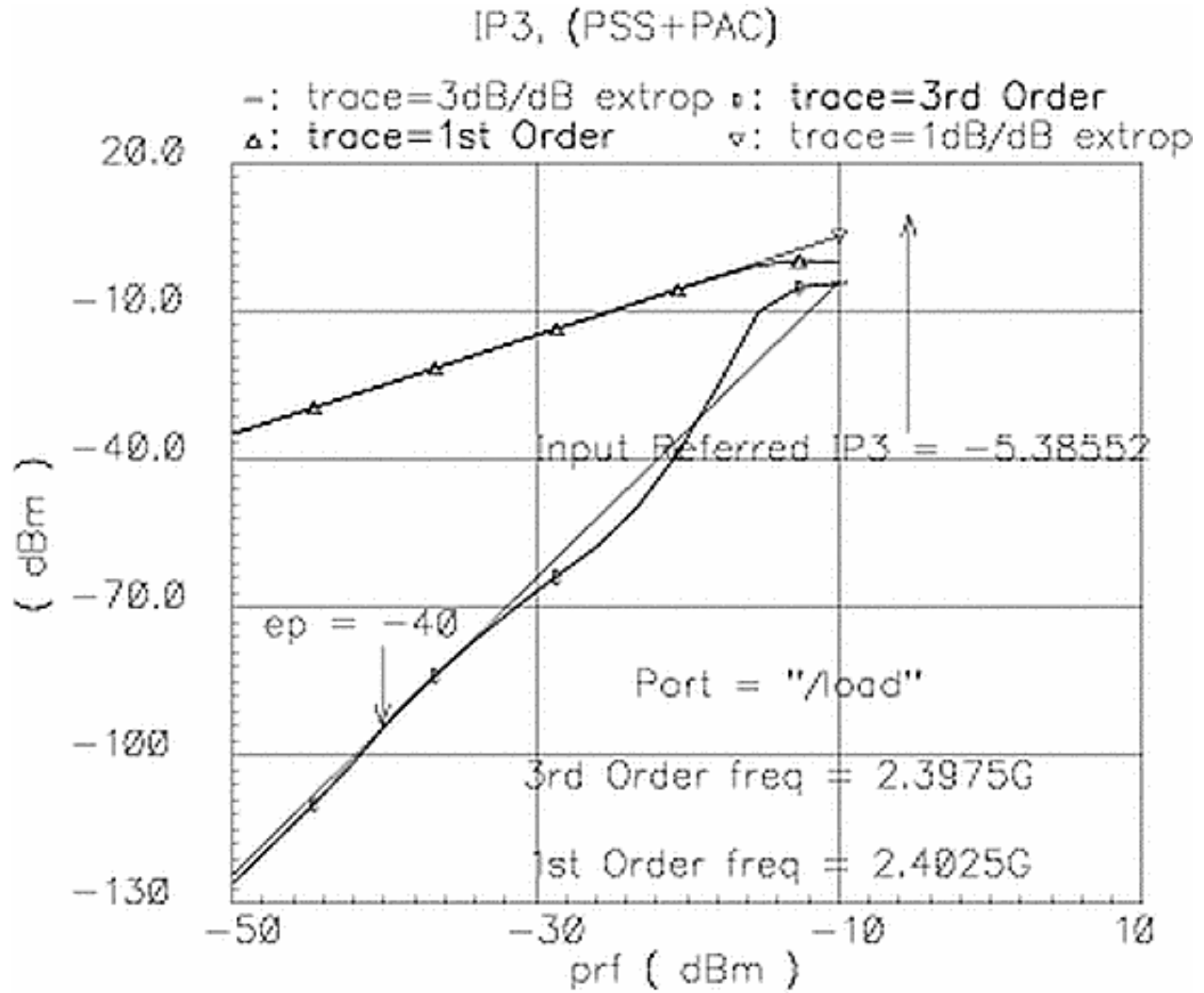

**Figure 1-22 IP3 for QPSS Analysis**

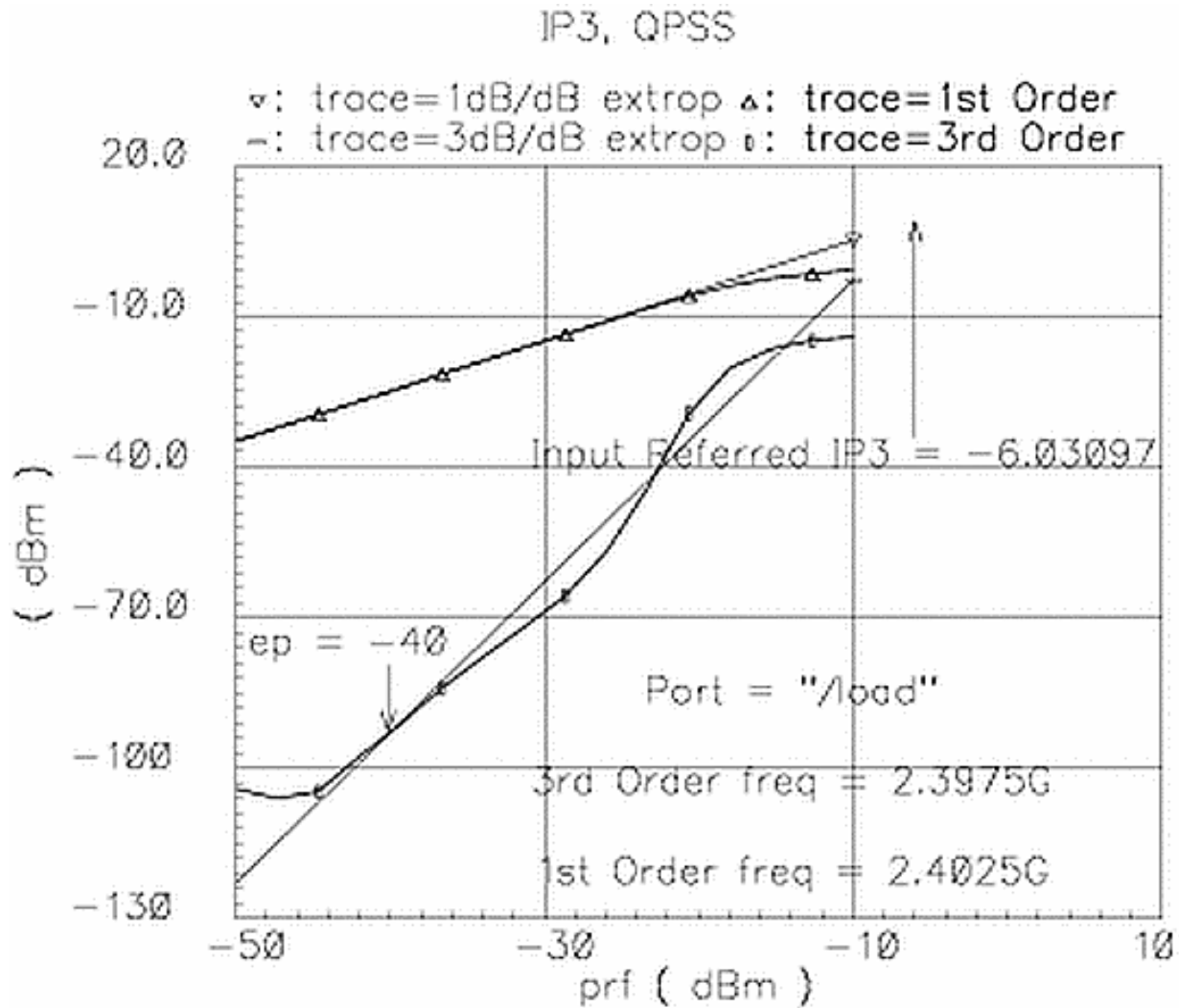

SpectreRF offers three ways to simulate IP3.

1. The first method treats one tone as a large signal, for example  $\omega_1$ , and performs a PSS analysis on this signal. The other tone, for example  $\omega_2$ , is treated as a small signal and a PAC analysis is performed based on the linear time-varying systems obtained after the PSS analysis.

The IP3 point is the intercept point between the power for the signal  $\omega_2$  and the power for the signal  $2\omega_1 - \omega_2$ . Since the magnitude of this component is  $0.75\alpha_3 A_1^2 A_2$ , it has a linear relationship with the power level of the tone  $\omega_2$ . Thus the  $\omega_2$  component can be treated

## LNA Design Using SpectreRF

### Low Noise Amplifier Design Measurements

---

as a small signal. It is necessary to set the power level of both tones the same. In the netlist, the input port and analysis settings are

```
rf (RFin 0) port r=50 num=1 type=sine freq=2.4G dbm=prf pacdbm=prf
sweep pss sweep param=prf start=-50 stop=-10 lin=15 {
pss pss fund=2.4G harms=40 errpreset=moderate annotate=status
pac pac sweeptype=absolute start=2.4025G maxsideband=10
}
```

2. The second method treats both tones as large signals and uses a QPSS analysis. In the netlist, the input port and analysis settings are

```
rf (RFin 0) port r=50 num=1 type=sine freq=frf dbm=prf fundname="RF"
+      freq2=frf+2.5M dbm2=prf fundname2="RF2"
sweep qpss sweep param=prf start=-50 stop=-10 lin=15 {
qpss qpss funds=["RF" "RF2"] maxharms=[7 5] errpreset=moderate
}
```

Both the first and second methods are equivalent because of the linear dependence of the output component's magnitude,  $2\omega_1 - \omega_2$ , on the input component's magnitude,  $\omega_2$ .

Figures [1-21](#) and [1-22](#) show the comparison between the two methods (PSS plus PAC method in Figure [1-21](#) and QPSS method in Figure [1-22](#)).

- The two tones are at 2.4 GHz and 2.4025 GHz
- The power levels for the two tones are swept from -50 to -10 dBm
- The calculated IP3 shows only 0.2 dBm difference

The recommended method is to use the PSS and PAC analyses for IP3 simulation because the PSS with PAC analysis method is more efficient than the QPSS analysis, and because the calculated IP3 is theoretically expected to be the same and is actually very close numerically.

3. The third method uses the PSS analysis with the beat frequency set to be the commensurate frequency of the two tones. Because the commensurate frequency can be very small, the simulation time for this method can be very long. This method is not recommended.

## Conclusion

This application note discusses LNA testbench setup, LNA design parameters, and how to use SpectreRF to simulate an LNA and extract design parameters. Some useful SpectreRF analysis tools for LNA design, such as SP, PSS, Pnoise, PAC and QPSS analyses are addressed. The results from the analyses are interpreted.

## Reference

- [1] “The Designer’s Guide to Spice & Spectre”, Kenneth S. Kundert, Kluwer Academic Publishers, 1995.
- [2] “Microwave Transistor Amplifiers”, Guillermo Gonzalez, Prentice Hall, 1984.
- [3] “RF Microelectronics”, Behzad Razavi. Prentice Hall, NJ, 1998.
- [4] “The Design of CMOS Radio Frequency Integrated Circuits”, Thomas H. Lee. Cambridge University Press, 1998.